

VIHOR

STREET LIGHTING

Modularity
Serviceability
Diverse optics

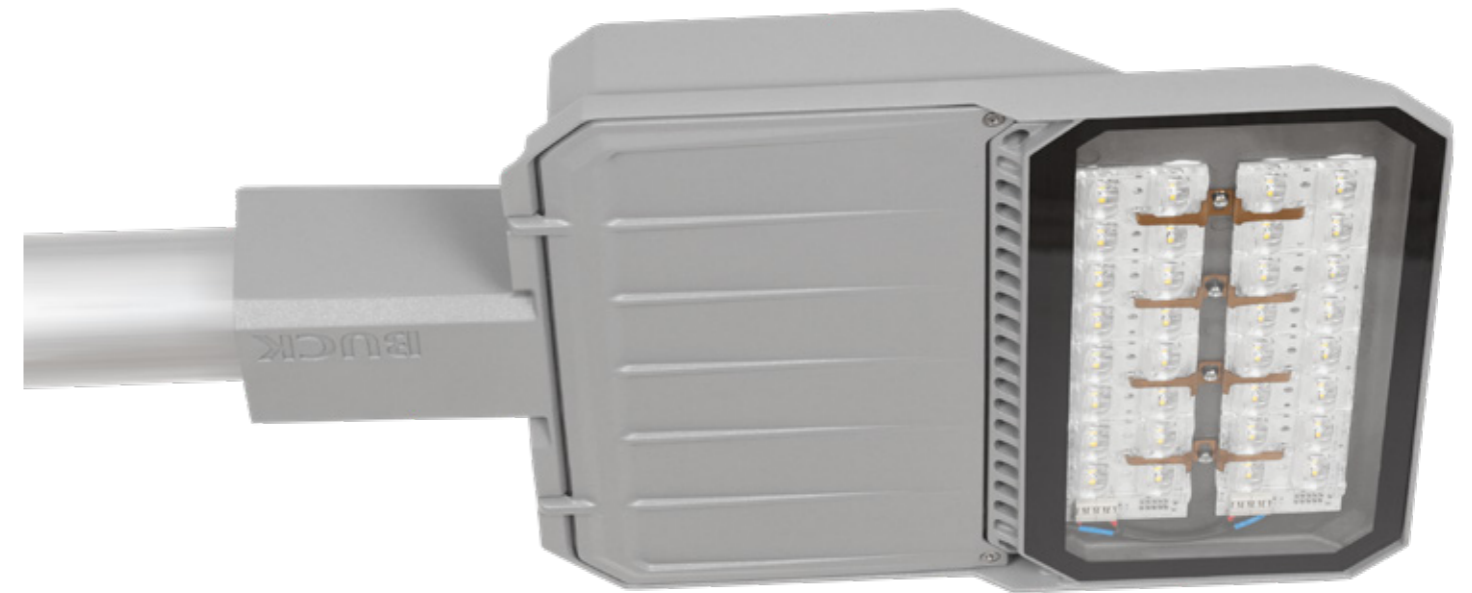

BUCK GmbH
Taunustor 1
60310 Frankfurt am Main
office@bucklicht.de
www.buck.lighting
tel +49.731.950.32.330

Copyright © 2018 BUCK

BUCK
www.buck.lighting

Large number of available light distributions caters for all requirements defined by EN 13201 regarding the quality of traffic illumination, particularly that of M2-M6, C1-C5, P2-P6, SC2-SC9, EV2-EV6.



LED street luminaire of high energy efficiency. Modularity, choice of 31 different lenses and different nominal powers enable continuous adjustment of power from 21W to 110W and flux adjustment from 2 798 lm to 12 585 lm. Lighting management and communication for smart energy consumption.

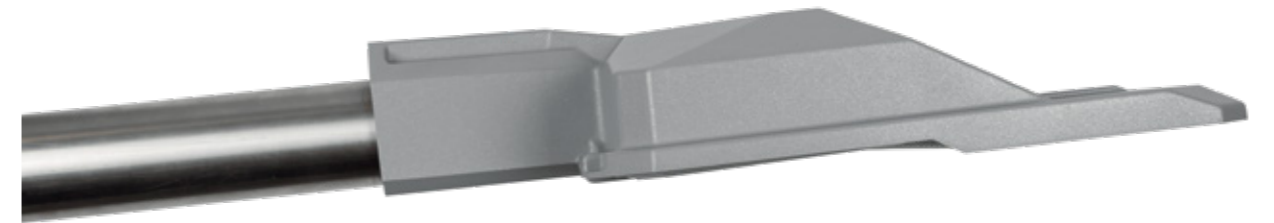

Ambient
temperatures
up to 40°C

ENERGY EFFICIENCY By choosing appropriate light distribution, depending on pole height and distance between poles, there are significant reductions in required installed power (compared to standard light sources).

Considering longevity of all components (>100,000h), the need for maintenance is reduced, leading to additional savings.

THERMAL MANAGEMENT

Excellent thermal management is obtained with specially shaped housing, which promotes convective heat dissipation and prevents dirt deposition. Control gear compartment and light modules are separated, preventing heat transfer to the gear, ensuring longevity and reliability of the luminaire.



The shape of cooling fins was inspired by natural shape of sand dune slopes.

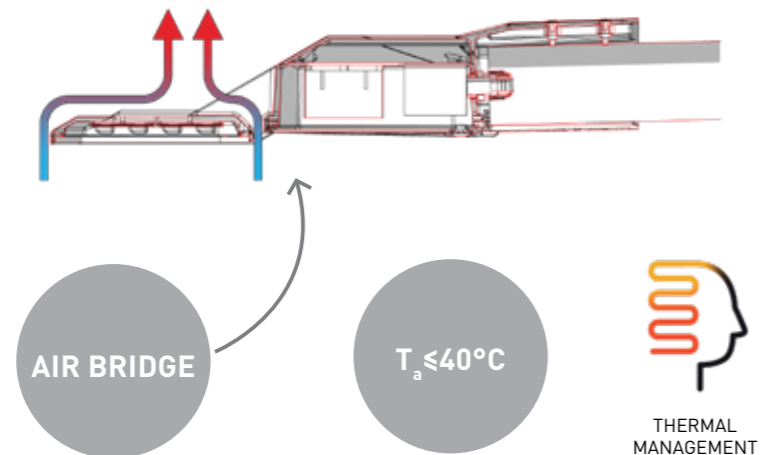



MODULARITY

Only one family of luminaires for illumination of different street types, regardless the speed limit, frequency etc., enabling the uniformity of street luminaires in the whole city area.

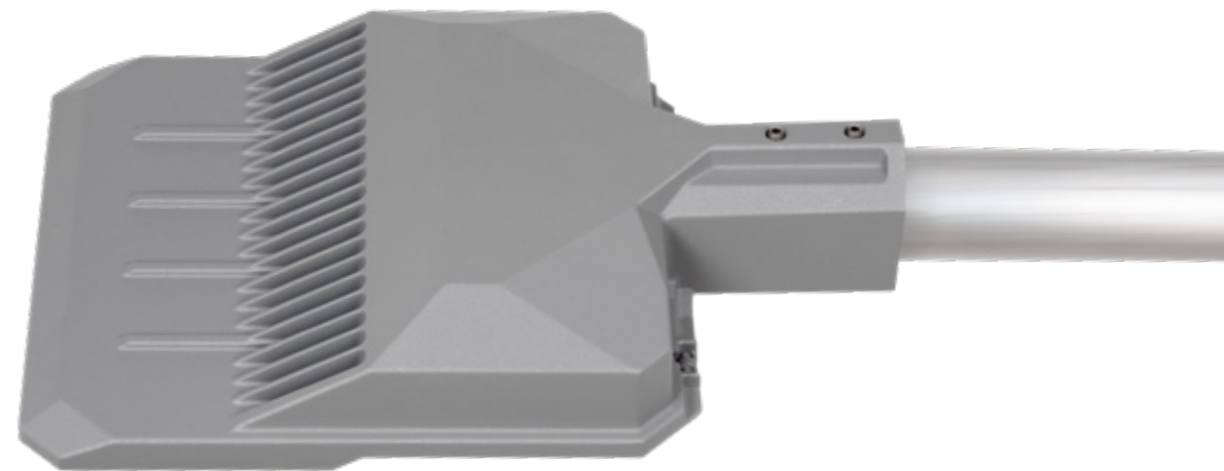

	DIMENSIONS A / B / H	LED LUMEN (4000K/CRI 70) MIN/NOM/MAX.	TOTAL POWER (W) MIN/NOM/MAX.	NUMBER OF LEDS	WEIGHT
VIHOR 12LED	445x302x95	2798/3502/4719	21/28/42	12	3.2
VIHOR 16LED	445/302/95	3731/4670/6292	28/37/55	16	3.2
VIHOR 24LED	445/302/95	5596/7005/9439	40/53/84	24	3.7
VIHOR 32LED	445/302/95	7462/9340/12585	53/72/110	32	3.7

OPTICS

PMMA lenses of high light transmission (95%) and a tempered, 4mm thick glass protector. Vast range of different powers and lenses cater for wide application in all types of outdoor illumination.

The distribution of light is defined by lenses made of optical grade PMMA with high UV and temperature resistance, appropriate for high current and temperature conditions. These lenses allow better targeting of light rays so that the light pollution and scattering to adjacent buildings are minimized. The lighting requirements that may occur in outdoor spaces such as roads, pedestrian zones, parking lots and squares can be met by choosing standardized lenses with appropriate light distribution.

- Optics efficiently prevent the light above the horizontal surface of luminaire (ULOR=0), eliminating light pollution.
- 4 standardized optics and additional 31 available on request.

3 000lm
to
12 000lm

PMMA LENSES
95% LOR



T2 OPTICS - BUCK VIHOR 12LED T2

CASE STUDY

Application of VIHOR with fewer number of modules and T2 lenses enables excellent uniformity of illumination of narrow streets or pedestrian lanes. Additional savings are obtained by reduced height of poles and greater spacing between them.
 Height: 8m, Overhang: 0m, Boom Angle: 10.0°

Lighting Class: M6	L_{av} (cd/m ²)	U0	UI	TI (%)	EIR
Calculated values	0.32	0.36	0.49	11	0.41
Required values according to class	≥0.30	≥0.35	≥0.40	≤20	≥0.30
Fulfilled/Not fulfilled	✓	✓	✓	✓	✓

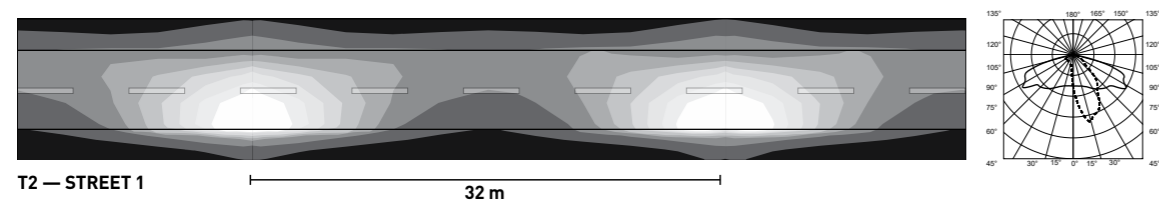

DWC OPTICS - BUCK VIHOR 24LED DWC

Application of VIHOR with DWC lenses and incrementation in number of its modules maximizes the spacing between poles. The illuminated area extends to two-way street and pedestrian zones on both sides.
 Height: 8m, Overhang: 1m, Boom Angle: 0°

Lighting Class: P3	E_{av} (lx)	E_{min} (lx)
Calculated values	7.58	4.45
Required values according to class	≥7.50	≥1.50
Fulfilled/Not fulfilled	✓	✓

Lighting Class: M4	L_{av} (cd/m ²)	U0	UI	TI (%)	EIR
Calculated values	0.76	0.48	0.62	10	0.47
Required values according to class	≥0.75	≥0.40	≥0.60	≤15	≥0.30
Fulfilled/Not fulfilled	✓	✓	✓	✓	✓

Lighting Class: P3	E_{av} (lx)	E_{min} (lx)
Calculated values	7.60	4.81
Required values according to class	≥7.50	≥1.50
Fulfilled/Not fulfilled	✓	✓

(All lighting performance requirements are met)

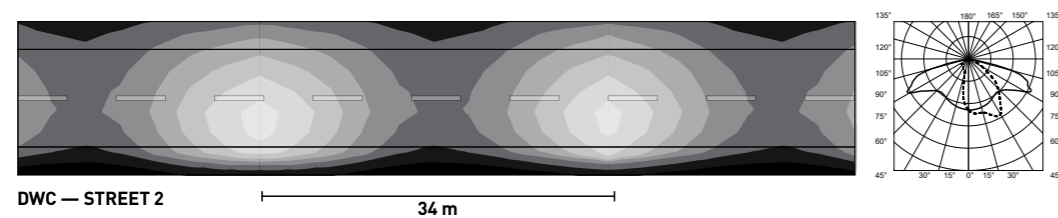

ME OPTICS - BUCK VIHOR 32LED ME

CASE STUDY

Application of VIHOR with ME optics and large number of modules provides illumination for regional roads, highways and access roads, with several lanes in both directions. Meets the requirements regarding high levels of luminance and uniformity (as for classes M3 and M4). Hight: 10 m, Overhang: 1.5 m, Boom Angle: 0°

Lighting Class: P2	E_{av} (lx)	E_{min} (lx)	Lighting Class: M3	L_{av} (cd/m2)	U0	UI	TI (%)	EIR
Calculated values	13.92	11.97	Calculated values	1.06	0.56	0.83	8	0.85
Required values according to class	≥ 10.0	≥ 2.00	Required values according to class	≥ 1.00	≥ 0.40	≥ 0.60	≤ 15	≥ 0.30
Fulfilled / Not fulfilled	✓	✓	Fulfilled/Not fulfilled	✓	✓	✓	✓	✓

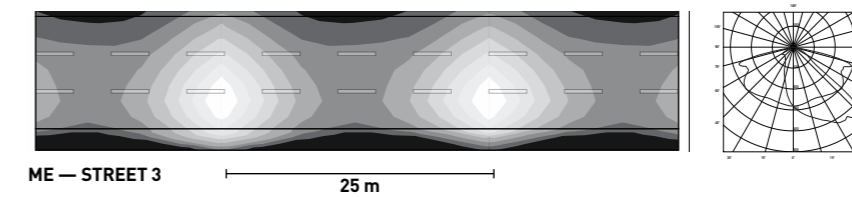

FN OPTICS - BUCK VIHOR 16LED FN

Specially designed for illumination of pedestrian crosswalk, VIHOR with FN lens meets the requirements for horizontal illumination to C1, with vertical illumination to EV2.

Lighting Class: EV2	E_v (lx)	Lighting Class: C1	E_v (lx)	U0
Calculated values	31.00	Calculated values	31.00	0.84
Required values according to class	≥ 30.00	Required values according to	≥ 30.00	≥ 0.40
Fulfilled / Not fulfilled	✓	Fulfilled / Not fulfilled	✓	✓

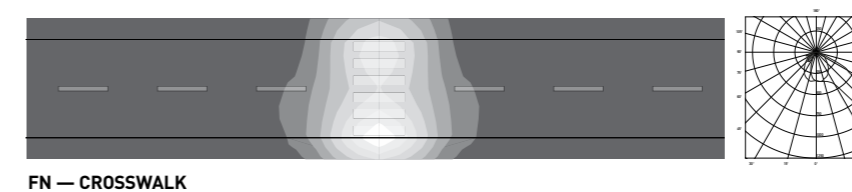

EFFICIENCY

The table compares the solution with existing luminaire using HQL 125W and the solution with VIHOR 12LED with standard tuning without optimisation and smart function and with standard tuning including all additional functions such as AOC, autonomous dimming, CLO.

Type	Installed power	Yearly energy consumption	Yearly energy consumption	Maintenance cost	Power savings	Energy savings	ROI period
	W	kWh/y	€/y	€/y	%	%	year
Existing: Street luminaire HQL 125W	150	602	108	27			
New: VIHOR 12LED without optimisation	28	112	20		81%	81%	1.46
VIHOR 12LED with optimisation	28	73	13		81%	88%	1.38

The table compares the solution with existing luminaire using HQL 125W and the solution with VIHOR 12LED with standard tuning, including all functions such as AOC, autonomous dimming, CLO.

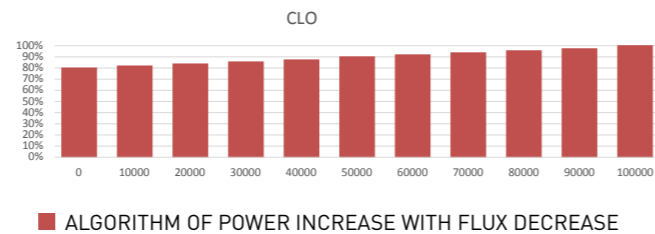
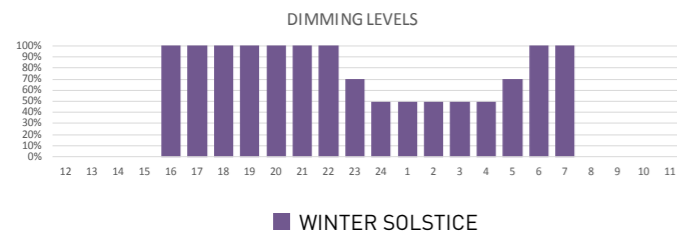
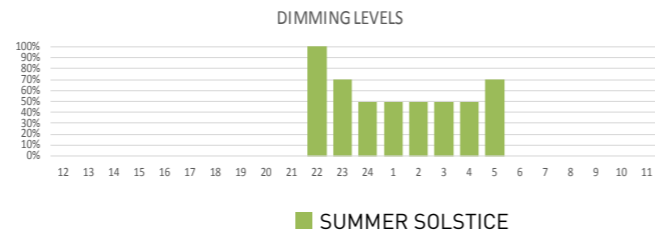
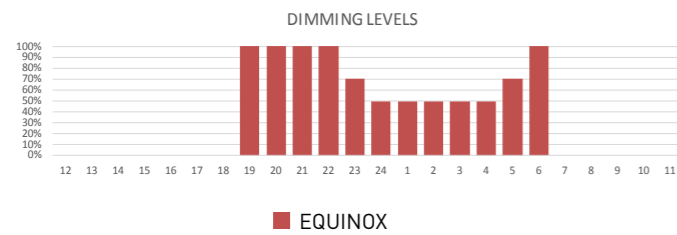

TECHNICAL DATA

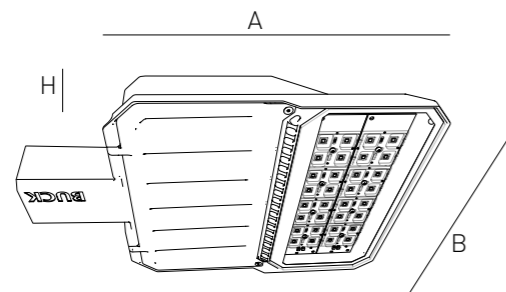

Dimensions A/B/H	445 / 302 / 95 mm
Ingress protection rating	IP66
Impact resistance rating	IK08 / IK10
Finish	black, gray, upon request
Weight	3.2-3.7kg
T_a	≤40°C
Lens LOR	>90%
Luminaire luminous flux (t_a=25°)	2798lm-12585 lm
Total power	21W-110W
LED efficiency	124-154 lm/W
Luminaire efficiency	92-115 lm/W
Luminaire LOR	>85%
Light colour temperature /CRI	3000K-5000K / 70-80
LED service life	>100.000h (L80B10)
Power supply	220-240V (198-264V), 50-60Hz
Constant current range	530-1050mA, 700mA NOM.
Control gear	ECG, DALI

The housing of the luminaire is made of die cast aluminium, protected by epoxy powder coating resistant to UV radiation.

Housing is modular and protected with 4mm thick tempered glass.

Complete control gear is mounted on a carrier which can easily be replaced in the field.



STANDARD EQUIPMENT

- Wireless interface communication
- Programmable
- AOC - Adjustable Output Current
- CLO - Constant light output
- Virtual midnight
- Protection against transient main peaks up to 6 kV
- Electronic short-circuit protection
- Overload protection
- Thermal protection
- Voltage range 198-264VAC
- Safety switch
- 1-10V analogue management

ADDITIONAL EQUIPMENT

- Power line communication
- Central management
- DALI communication
- Protection against transient main peaks up to 10 kV
- Voltage range 150-264VAC

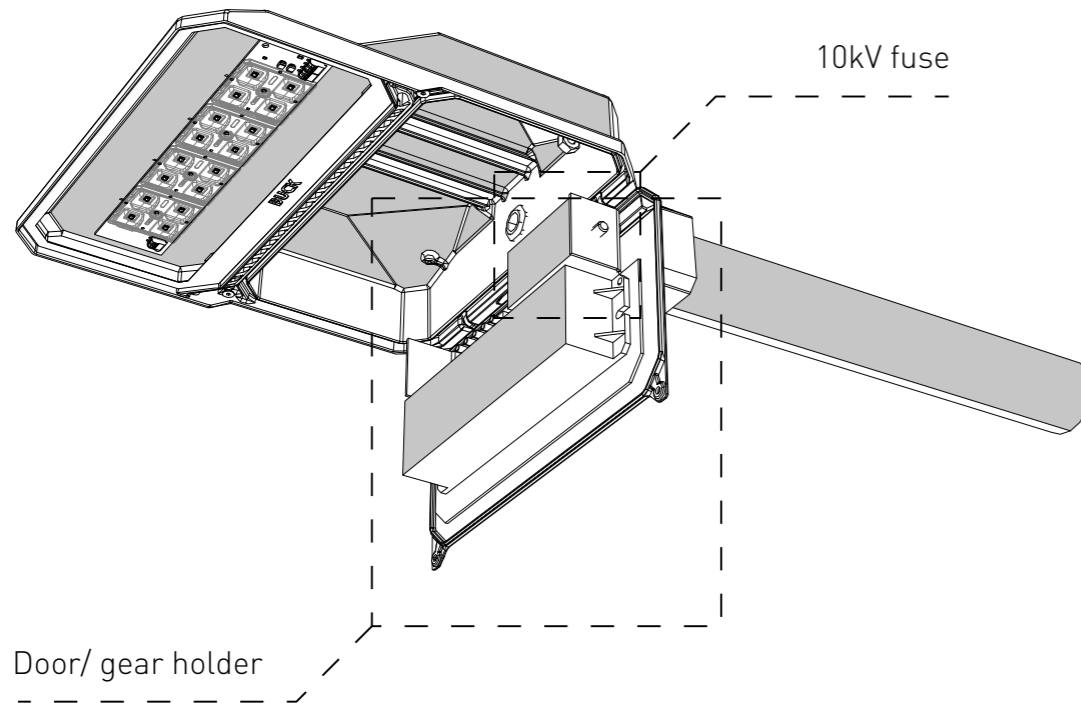

EASY SERVICEABILITY



ACCESS TO ELECTRICAL COMPONENTS WITH BASIC TOOLS



The luminaire is programmable directly at the mounting site via wireless interface communicator.



SERVICEABILITY

Easy access to electrical components. Inspection door serves as control gear holder, for quick replacement or upgrade to new generation.

Possibility to perform maintenance by merely replacing the door with a spare one, using quick connectors, without interruption in illumination level or operation of the whole lighting installation.



SIMPLE
UPGRADE



MOUNTING

Mounting directly on arm \varnothing 60 mm (side entry 42- 60 mm).

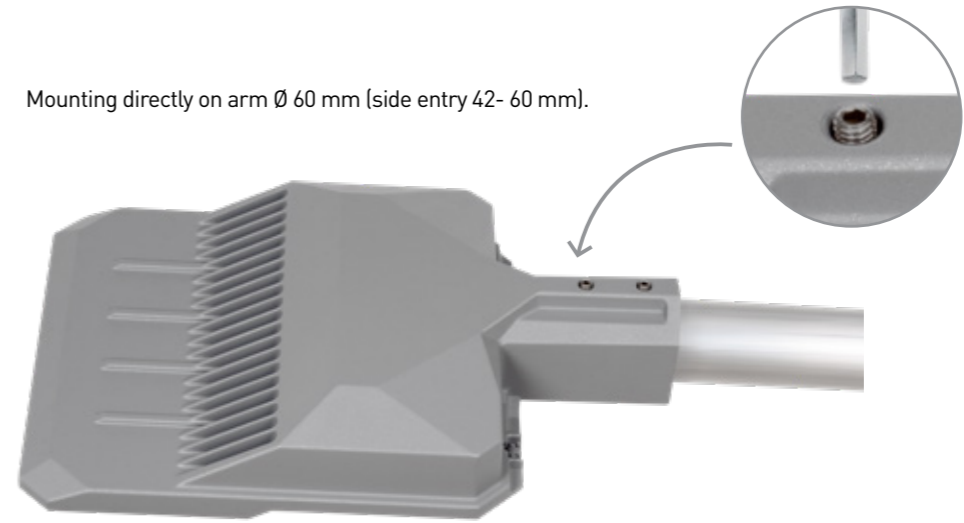

Mounting directly on the top entry \varnothing 60 - \varnothing 76 mm with adapter.



Adapter angle adjustment mechanism



Mounting on side entry \varnothing 60 - \varnothing 76 mm with adapter.



SMART CITY

A smart city is an urban development vision integrating multiple information and communication technology (ICT) and Internet of Things (IoT) solutions in order to manage city assets (such as local departments' information systems, schools, libraries, transportation systems, hospitals, power plants, water supply networks, waste management, law enforcement and other community services).

The goal of building a smart city is to improve the quality of life by increasing efficiency of city services and meeting the citizen needs. Using sensors integrated with real-time monitoring systems, data are collected for processing and analysis. The information and knowledge gathered are keys to tackling inefficiency.

INTERNET OF THINGS

Internet of things (IoT) is a term denominating general connection between electronical devices that are able to collect, generate and send various types of information. This enables the analysis and cross-reference of the data acquired and prompt actions in real time.



INFORMATION AND COMMUNICATION TECHNOLOGY (ICT)

Information and communication technology (ICT) is used to enhance quality, performance and interactivity of urban services, to reduce costs and resource consumption and to improve connection between citizens and local government.

Smart city applications are developed with the goal to improve the management of urban flows, allowing real time responses to challenges.

Illustration of smart city components and the way technology can integrate with many sectors for service enhancing.



STREET LIGHTING OF SMART CITIES

Street lighting represents an important component of smart cities. In addition to the basic function of the control and regulation of the brightness of street lights, it may include:

1. Smart Traffic Management

Street lights can be equipped with cameras or sensors, allowing detection of movement. Additional technology enables the street lights to communicate with one another. When a passer-by is detected by a camera or sensor, this information will be communicated to neighboring street lights, which will brighten so that people are always surrounded by a safe circle of light.

2. Lighting Control and Energy Optimization

Energy savings and lighting optimization are primary drivers for lighting upgrades, focusing on improving management of lighting, energy and maintenance for all light fixtures on the network.

3. Public Safety and Security

The solution includes video, sound and motion-capture capabilities that enable security services management (parking lots and garages, city streets in need of enhanced security, asset protection and perimeter detection). It is possible to stream video and provide edge-based intelligence for analyzing data at the capture point. It is also possible to transmit the analytics, along with alerts to a central cloud database and to the appropriate agencies based on system rules.

These edge-based, real-time analytics can include:

- Configurable events and alerts that can trigger lighting conditions and other actions.
- Cost-effective extension of the security perimeter.
- License plate or facial recognition, etc.

4. Smart Parking

Gathering real-time parking availability data, the solution makes this information available to parking-application providers. These data enable real-time wayfinding, dynamic pricing and parking management. By using common infrastructure, cities can reduce the hardware cost and service fees associated with traditional smart-parking deployment.

- Lower vehicle miles traveled and carbon emissions
- Improve the parking utilization
- Optimize parking revenue through dynamic pricing

5. Location Analytics

This denomination includes traffic counts by location or time of day, number of visitors and visit duration, offering key information to managers of airports, malls or business districts.

The data collected by the platform allows location analytics to generate:

- A deeper understanding of populations served;
- Detailed reports comparing traffic over time;
- Traffic counts by visit frequency and duration.

STREET LIGHTING ENHANCED WITH SMART CITY FUNCTIONS

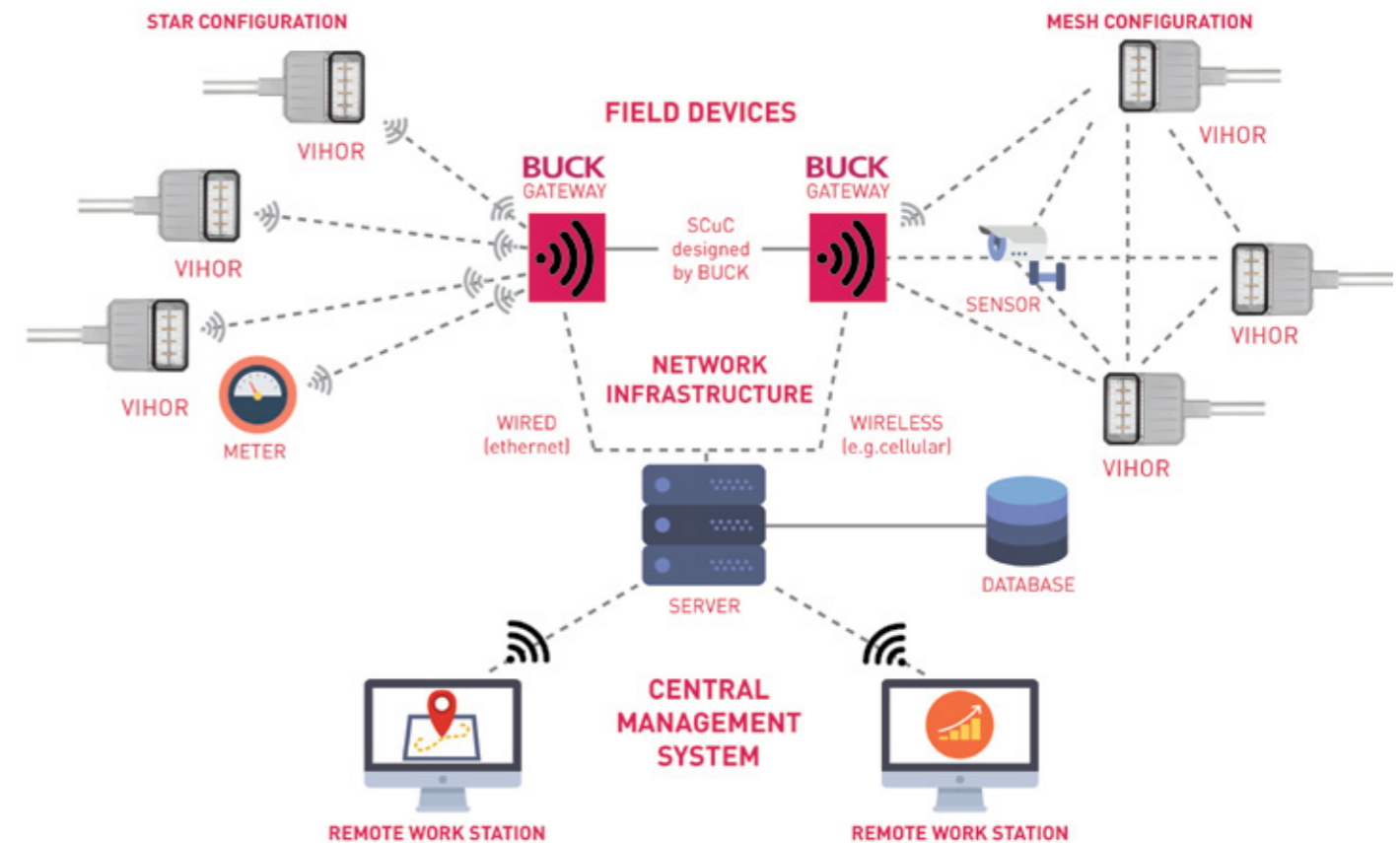

HIGHLIGHTS

Functions of street lighting enhanced with smart city functions:

- Drastically reduce city energy consumption, costs and maintenance using LED technology combined with dynamic, per-unit or group controls;
- Improve citizen vehicle compliance and increase violation capture and city revenues;
- Enhance situational awareness, real-time collaboration and decision making across city agencies, helping optimize urban planning;
- Add intelligent, sensor-based Internet-of-Everything (IoE) innovations to transportation, utilities, public safety and environmental monitoring without adding significantly more physical infrastructure.

